

# 10 MeV 25KW INDUSTRIAL ELECTRON LINAC

Y. Kamino

Mitsubishi Heavy Industries, Ltd. Nagoya Aerospace Systems  
10 Oye-Cho Minato-ku Nagoya,455 Japan

## Abstract

A 10 MeV 25 KW class electron LINAC was developed for sterilization of medical devices. The LINAC composed of a standing wave type single cavity prebuncher and a 2 m electroplated traveling wave guide uses a 5 MW 2856 MHz pulse klystron as an RF source and provides 25 KW beam power at the Ti alloy beam window stably after the energy analyzing magnet with plus-minus 1 MeV energy slit. The practical maximum beam power reached 29 KW and this demonstrated the LINAC as one of the most powerful S-band electron LINACs in the world. The control of the LINAC is fully automated and the "One-Button Operation" is realized, which is valuable for easy operation as a plant system. 2 systems have been delivered and are being operated stably.

## Introduction

A 20 KW (beam power) class LINAC has the greatest market in the electron beam sterilization market. Several types of 20 KW class S-Band (2856 MHz or 2998 MHz) LINACs have been developed and marketed but most of them are unstable at the 20 KW operation and the practical beam power is limited to under 20 KW range. Under this situation, a small, stable and efficient S-Band sterilization LINAC with the capacity of 25 KW plus class (marginal beam power) is looked forward to for an expanding sterilization needs. We have developed a 25 KW plus class sterilization LINAC system successfully and two systems are operated at the customer's plant stably. In this paper, the detail of this new age 25 KW plus class S-Band electron LINAC is presented.

## Design Concept

The main cause of the instability of most of the S-Band LINACs is the thermal instability of the accelerator guide under an intense heat load. In some cases, 20 to 30 KW RF power is dissipated in a 1 to 2 m accelerator guide with less than 10 cm diameter cavities. Beam loss in the accelerator guide gives an additional lumped heat load to some part of the accelerator guide where the beam is lost. The intense and uneven heat load distorts the cavities of the accelerator guide to destruct a correct acceleration phase relationship and cause the beam instability.

Our design concept is to reduce the RF loss and beam loss to the theoretical limit.

## System Outline

The system construction is shown in Fig. 1. The system block diagram is shown in Fig. 2. The operational parameter and the performance is as follows.

Beam Energy	: 10 MeV variable from 9 to 11 MeV
Energy Spread	: 1 MeV (90% beam current)
Beam Power at beam window	: 25 KW (guaranty) PPS = 550 Hz 29 KW (actual) PPS = 630 Hz
PPS	: 700 Hz (Max)
Beam pulse width	: 13.5 micro sec (nominal)
Beam current	: 340 mA peak (nominal)
Frequency	: 2856 MHz
Klystron power	: 5 MW peak
Irradiation Surface	: 60 cm from the beam window
Beam spot size	: 16 cm diameter on the irradiation surface
Beam Scan Width	: 30 cm to 80 cm variable
Scan Uniformity	: within plus minus 5% (guaranty)

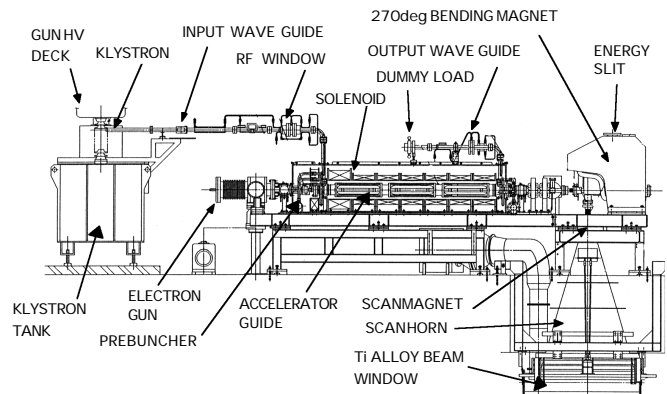

Fig. 1: System construction (accelerator side view).

## Accelerator Guide

A traveling wave CG type guide is selected because a circulator and dummy load system for the input wave guide which constitutes a major loss can be deleted with the traveling wave guide and the klystron output port can be connected directly to the input port of the accelerator guide. The guide parameter is selected as 2 m long (60 cavities) and 0.38 Neper (attenuation factor) CG type to get the 10 MeV beam energy at the nearly heaviest loading condition with available klystron power of 4.8 MW at the guide input by the load line analysis. The beam current is 360 mA. The initial 8 cavities of the accelerator guide is the tapered buncher section and the disk spacing is determined by the electron phase analysis to get the best bunch suppression ratio for a tight energy spectrum and the phase limit of -90deg (just on the crest of the accelerating field) for the best energy conversion efficiency. The energy conversion efficiency of the accelerator guide with the injection in the next paragraph is as high as about 70% (measured value) and nearly the theoretical limit. This good energy conversion efficiency reduces the heat load of the accelerator guide to as low as 10 KW (average) under the 25 KW beam power operation.

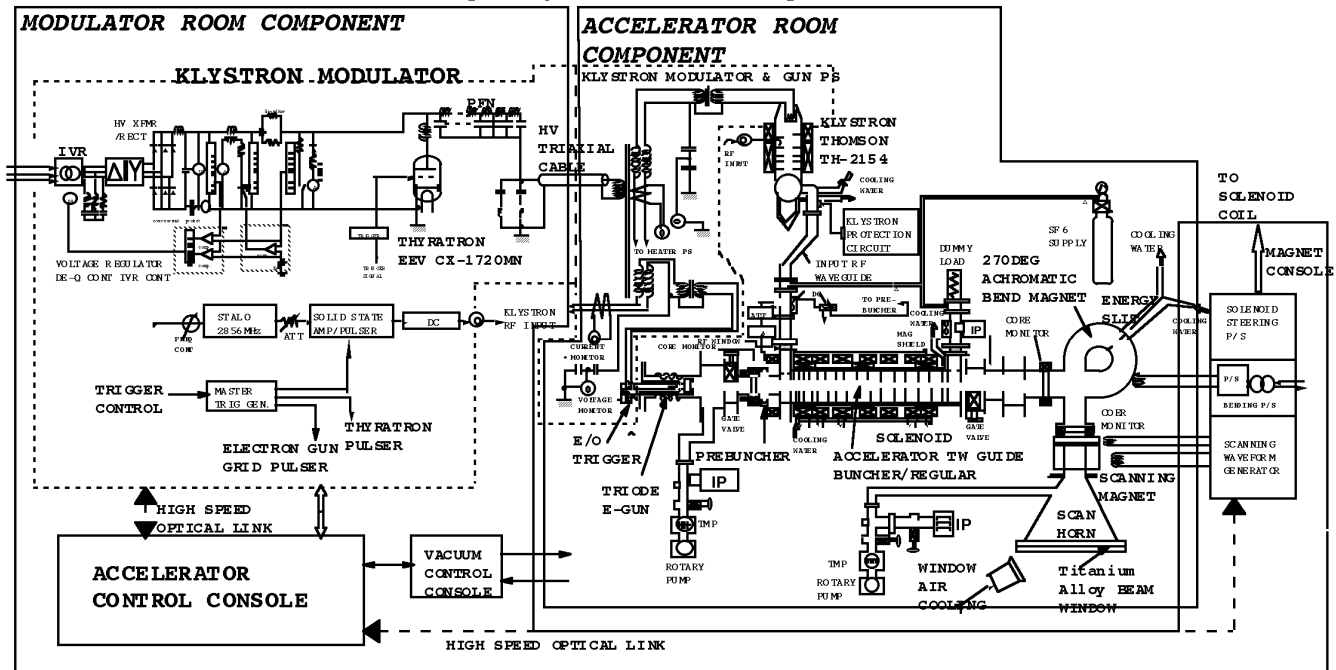

Fig. 2: System block diagram.

The new cooling scheme of the accelerator guide - *ADAPTIVE COOLING* (PAT. Pending) is introduced to control the phase relationship under the intense and uneven heat load.

### Injector

The electron gun is a triode gun. A rather high gun voltage (140 KV) is selected for a better capture of injected electron beam at the buncher section. The gun voltage is supplied from the klystron modulator as a pulse voltage from the pulse transformer for the klystron. The electrode geometry of the electron gun is designed with simulation code E-GUN to get the best optics at the designed beam current of 400 mA. The gun cathode assembly is CPI EIMAC Y-845. The electron gun has a grazer type magnetic lens to compensate the variation of the optics due to the mounting tolerance of the cathode. The beam current is controlled by the grid voltage and stabilized with a feedback control. The current stability is less than plus minus 1% for a long period of operation.

The prebuncher cavity is a nose reentrant type cavity to suppress a multipactor discharge. The cavity is made of OFHC and the RF power is supplied with a over-coupled condition (coupling coefficient  $\beta = 30$ ). The effective Q factor is 300. This coupling scheme realizes a broad frequency characteristics to allow the frequency control of the accelerator guide (for reactive beam distortion compensation and adaptive cooling) and to reduce the phase and amplitude perturbation due to the beam loading.

### Beam Dynamics

The beam dynamics is evaluated with PARMELA. The calculated and measured transmission efficiency are 90.2% and 90% respectively. Both values coincide fairly well. The calculated and measured beam profiles coincide well both in the spatial distribution and in energy distribution. The system is designed as a practical production machine and can not accommodate a Faraday cup and a slit for quantitative energy analysis. The energy spectrum is measured with a fluorescent plate (Desmarquest AF995R) at the slit position. The beam profile (Fig. 3) shows that the almost all current is included in the range of 1 MeV. The FWHM is about 0.4 MeV. There is no low energy tail which is usually observed for the industrial and medical LINAC systems which becomes a large amount of current integrated over a wide energy range and constitutes a large amount of beam loss at the energy slit. There was some high energy component observed but the component disappeared after the gun triggering timing alignment to the RF pulse to compensate an initial beam loading effect. The beam loss in the accelerator guide is 10% and the beam loss of the energy slit is 5%. The total beam loss between the electron gun and the beam window is only 15%.

The heavy beam loading causes a reactive phase distortion. This is compensated by adjusting the RF frequency upward by about 200 KHz to get the heaviest beam loading [1, 2].

### Beam Break Up Consideration

The beam break up (BBU) is evaluated thoroughly, because a longer pulse width (13.5 micro sec) compared with other existing LINAC and a rather large beam current (400 mA) will lead to the BBU which results in a fatal failure in satisfying the performance specification.

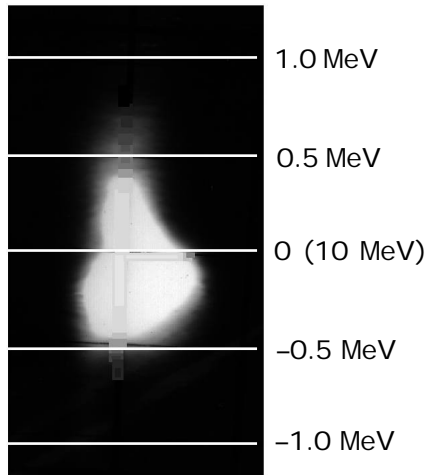

Fig. 3: Energy spectrum measured at the energy slit. Energy analyzed beam profile at the energy slit position on Desmarquest AF995R plate.

A Regenerative BBU (R-BBU) is the BBU expected for this LINAC. The starting current of R-BBU is inversely proportional to the electron beam energy and occurs at the initial part of the accelerator guide where the electron beam energy is low. In CG type accelerator guide, HEM11 modes excited in the upper stream region can not go through the down stream region, because the HEM11 modes excited in the upper stream region fall in the stop band in the down stream region and are trapped and become standing waves. The 15 cavities (tapered buncher section-8 cavities and initial part of CG section-7 cavities, 15 cavities in total) are modeled and all dipole modes are sorted out with MAFIA. There are 10 dipole modes. In these dipole modes, pi-like modes are selected and three modes with the highest shunt impedance are evaluated as follows. The starting current estimation is based on Wilson's method [3, 4] including the effect of the magnetic focusing and the pulsed nature. The following value is a rough estimation, but a great margin is secured for 400 mA operation. There is no indication of BBU observed in the real operation and the beam pulse shape is quite stable.

<u>Mode</u>	<u>Dipole Mode Freq.</u>	<u>Starting Current</u>
No. 3	4213.2 MHz	3.25 A
No. 4	4226.8 MHz	2.10 A
No. 5	4234.8 MHz	3.09 A

### Klystron Modulator

The klystron modulator is a line type pulser with a high average current thyatron (EEV CX-1720MN) as a main switching device. The command charging is introduced to secure the recovery time of the thyatron and a long life of PFN capacitors by minimizing the HV time of the capacitors. The klystron is Thomson TH-2154.

### System Control

The whole accelerator system is controlled by a Programmable Logic Controller. A whole monitor and control function is integrated on a LCD touch sensing panel to realize 'ONE BUTTON CONTROL'. The communication with other computer system is provided to realize a fully remote control and one-man operation of a whole sterilization plant. The accelerator system reaches the predetermined operational condition from the stand-by mode in 1 minutes after the start up command full automatically.

### Conclusion

A 10 MeV 25 KW plus class electron LINAC for sterilization of medical devices is successfully developed with the state of the art LINAC technology. Two systems are being operated stably at the customer's sterilization plant.

### Acknowledgement

The author is grateful to Dr. P.B. Wilson of SLAC for his assistance in study of beam break up theory and Dr. J.W. Wang, also of SLAC for his theoretical assistance and prebuncher development. The author is grateful to engineers at Nihon Koushuha Co. Ltd. for their contribution in developing a Klystron modulator and RF components (RF window, etc).

The author is grateful to HOGY Medical Co. Ltd. for giving him the chance to develop the significant system and various valuable suggestions as a pioneer in the field of commercial high energy electron beam sterilization in Japan.

### References

- [1] S. Arai et al., "Detuning effect in a traveling-wave accelerator structure due to beam loading", Particle Accelerators, 1984, vol. 15, pp. 99-114.
- [2] S. Arai et al., "Detuning effect in a traveling-wave electron LINAC", Particle Accelerators, 1984, vol. 15, pp.115-136.
- [3] P.B. Wilson, HEPL Report 297, June, 1963.
- [4] P.M. Lapostolle and A.L. Septier, "Linear Accelerators", North-Holland Publishing Company, 1970, pp. 190-192.