

LANSCE 201.25 MHz DRIFT TUBE LINAC RF POWER STATUS*

J. T. M. Lyles and C. C. Friedrichs, Jr.
 Accelerator Operations & Technology
 Los Alamos National Laboratory
 Los Alamos, NM 87545 USA

Abstract

The Los Alamos Neutron Science Center (LANSCE) linac provides high power proton beams for neutron science, Tritium target development, nuclear physics, material science, isotope production, and weapons research. The number of simultaneous beam users places heavy demands on the RF powerplant, especially the 201.25 MHz power amplifiers (PA) driving four drift tube linac (DTL) tanks. Designed nearly 30 years ago, these amplifiers have operated at up to 3 Megawatts with duty factors of 12%. The large number of power tubes in the PA and Intermediate Power Amplifier (IPA) plate modulators, the age of the cooling and control subsystems, tube manufacturing problems, and operation near maximum PA tube ratings have all affected the system reliability.

By monitoring final power amplifier plate dissipation and tube vacuum, improved operating procedures have raised RF system reliability above 95% for operation periods in 1993-95. Other recent modifications and upgrades to the 201.25 MHz RF powerplant have significantly improved the operation. Higher beam current for a proposed Long Pulse Spallation Source (LPSS) cannot be delivered simultaneously with other beams at high duty factor, however. Plans are underway to develop a new final power amplifier which can use low-level RF modulation for amplitude control. With only a few power tubes, the system will deliver high peak power and duty factor, with improved DC to RF efficiency, and a simplified cooling system.

Overview of Original 201.25 MHz RF Systems

A block diagram of the original 201.25 MHz RF system is shown in Figure 1. The maximum duty factor is 12% where the plate dissipation of the final amplifier tube (Burle Industries 7835 triode) is approximately 250 kW. A selection of the 7835 parameters is given in table 1. The peak power out of the final cavity amplifier is over 3.0 MW in some cases. The amplifier chain used a solid state preamplifier and a dual tube driver to provide 4 kW output. This output drives the IPA, a Burle 4616 tetrode, to achieve 130 kW. Finally the 7835 PA can deliver over 3 MW.

The 7835 cavity amplifier is unstable if operated with B+ but no RF drive, so the input high voltage is modulated by the

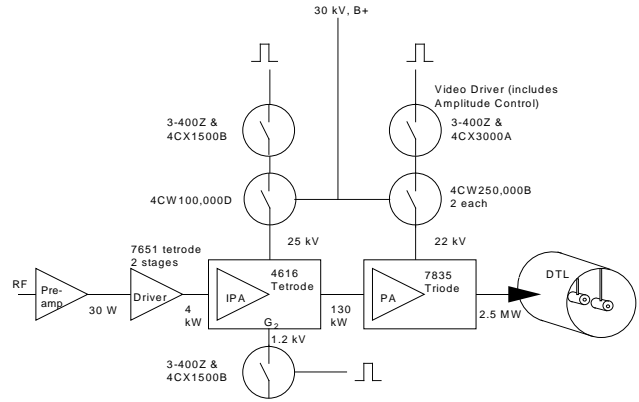

Fig. 1. Original 201 MHz Amplifier System.

Table 1
 Burle 7835 Electron Tube Parameters

Type	Cathode-Driven Triode
Gain	13.6 dB
Designed	1960
Filament	Thoriated Tungsten
Filament V	4 V
Filament I	6800 A
Plate Dissipation	300 kW
Plate Voltage Max	40 kV
Water Flow	200 GPM

amplitude control electronics in order to adjust the saturated output and thereby provide the amplitude control. This high voltage modulation technique requires four power tubes. The modulator has an internal voltage drop of 8 to 12 kV, so the high voltage capacitor bank must be maintained with that head room above the level needed by the 7835. At the present peak powers, the 7835's require 19 to 21 kV, and the capacitor bank operates at approximately 30 kV. Operation above this level not only stresses the capacitor bank and power supply, but stresses the modulator tubes.

The IPA high voltage is derived from the same high voltage as the PA. The IPA operates as a linear amplifier, so the high voltage is only switched on and off. Its level is not modulated as in the case of the final amplifier. A tube-based modulator is used to switch the high voltage on the 4616, requiring 3 power tubes (fig. 1).

*Work supported by the US Department of Energy.

Modifications and Upgrades to 201.25 MHz RF Systems

In the original configuration, the entire 201.25 MHz amplifier system required thirteen power tubes per module times four modules, or fifty-two power tubes. Recent modifications have reduced that number to nine per module [1,2]. These included the 1994 installation of a solid-state driver and a solid-state screen grid (G_2) pulser for the IPA stage. These are included in fig. 2. An upgrade is planned for the near future in which the IPA will have its own high voltage power supply (HVPS). This will eliminate the three-tube HV modulator and bring the total tube count per module to six. When the IPA HVPS is installed the 201.25 MHz system will be arranged as in Figure 2. This upgrade is just beginning with the purchase of a prototype HVPS, due for arrival in late 1996.

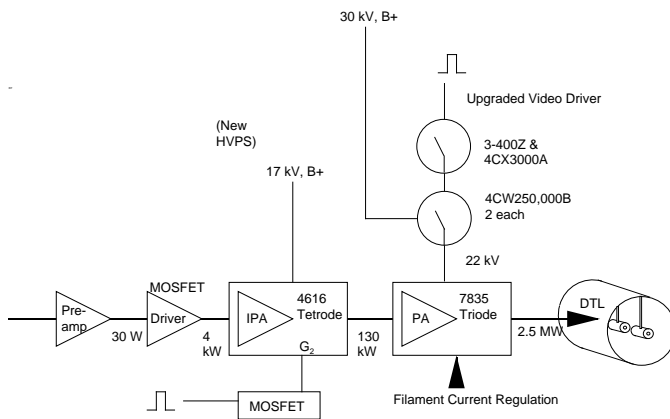

Fig. 2. 'Upgraded' 201 MHz Amplifier System.

Plate Power Dissipation Monitors

The original specification for the 7835 super power triode lists the average plate dissipation limit of 300 kW (Table 1). LANSCE has operating experience which suggests that for safe operation, dissipation should be below 250 kW. Real time monitoring of the average plate power dissipation of the FPA was installed in 1993 [3]. Using the temperature difference in the plate coolant manifold and the flow from a sensor, the power wasted in the plate coolant (plus a factor for filament and drive power) is computed with an embedded controller and used for readout and interlock of the HV. We implemented administrative controls to limit the operation to plate dissipations of less than 250 kW. Catastrophic failures have been significantly reduced. This is especially effective during beam tuning and transient start-up conditions when the RF power level is fluctuating and the resonance controller is moving the DTL tuning slugs.

Peak Power Monitors

Another significant improvement was the addition of peak power monitors (PPM) to indicate RF power levels in Watts

for the entire amplifier chain. The PPM replaced original uncalibrated detector diodes and directional couplers which were only useful for indicating that a signal was present. We purchased commercial directional couplers in 5 kW, 150 kW, and 3 MW "sizes", for the driver, IPA, and PA outputs, respectively. Lowpass filters eliminate harmonics from the power signals. A PPM timing gate allows sample/hold of the peak anywhere in the RF waveforms. These signals are fed to large LED displays, and to the central control room for logging. Both forward and reflected power are monitored, using custom versions of the Narda 481 diode power monitors. Linearity is ± 0.25 dB over a 10 dB dynamic range.

Filament Power Regulator

The original 7835 PA filament supply was an unregulated, variac-controlled supply. As noted in table 1 above, this supply delivers over 30 kW of DC power. A modern SCR supply was purchased for our test stand to see the benefits of filament current regulation. The regulation has been shown to be effective in stabilizing the 7835 operation, since the cathode current in the grounded-grid triode is proportional to emission from the filament. However, because of the cost of the filament supply and the desire to replace the 7835 amplifier stages in the near future (see below), we have chosen to modify our existing supplies rather than make new purchases. The modification consist of adding a control circuit to the power supply which adjusts the variacs as the supply output current varies. In order to avoid excessive brush wear in the variacs, the control circuit is designed with an adjustable dead band. We have found that 50A is a suitable band. The regulation is sufficient, and the brush movement is not excessive. The regulator is isolated and filtered to ignore the pulsed cathode bias voltage which is common to both filament connections.

Modifications to the PA Plate Modulators

In 1992, analysis of the PA plate modulator output waveforms showed an undershoot of about 5 kV after pulse shutoff. The cutoff 7835 triode was acting as a rectifier for the returning RF power spike from the DTL tanks during decay. A high power clamp diode was connected from the floating deck to ground, eliminating the negative transient which was charging the deck. This modification dramatically reduced nuisance crowbars due to modulator tube faults. Current transformers were also added to monitor screen current and the plate current in each 4CW250,000B tetrode. These diagnostics have allowed us to predict when a driver or modulator tube is weakening and plan a changeout in advance [1, 2].

The modulator driver tetrode (4CX3000A) filament and screen power supplies were modified with the addition of ferroresonant (constant voltage) transformers. This stabilized the overall modulator loop gain for line voltage fluctuations, and has doubled driver tube lifetime by allowing us to hold closer tolerance to optimal filament temperature. Because of

the screen voltage regulation, linac fill time is improved when the driver tetrode operates saturated.

We have installed new bias power supplies for the 4CW250,000B tetrode modulator tubes which allow a higher control grid bias: 500 versus 350 volts negative. This cuts off the tubes more completely during the beam-off time, to minimize cutting of the anode of the tube from the electron beam, which is focused in this condition. The new bias supplies are modular units which are very easy to replace compared to the original hard-wired supplies. Safety is enhanced with the new bias power supplies, and modulator tube life is extended.

Solid State Amplifier

The second stage of solid state amplification in Figure 2 was a recent upgrade which replaced a dual-tube amplifier [1]. The original Burt 7651 tetrode driver tubes had a short lifetime due to a cooling design limitation. They were adequate at low duty factor, but the present duty-factor raised the ceramic seals in some units to near 250°C. New water-cooled solid state amplifiers, using thirty-two Motorola MRF141G MOSFETs combined to deliver up to 5500 W, were installed in 1993 and 1994. Reliability is now excellent with these units. In addition, an entire rack of power supplies, blowers, and amplifier cavities has been eliminated for each 201.25 MHz amplifier system.

Capacitor Room and Crowbar Upgrade

The first level of arc protection for the FPA and IPA RF tubes is provided by a modulator blocking circuit. That is, in the event of an RF tube arc, the modulator switch tubes are shut off as rapidly as possible. In addition, the crowbar trigger circuit waits on the order of 10 μ s for the modulator to extinguish the fault current before commanding the crowbar to fire. This long delay time forces a requirement for a 10 Ω fault limiting resistor which must dissipate about 70 kW in normal operation. The resistor is immersed in an oil tank, and the oil is cooled by a heat exchanger external to the capacitor room. Maintenance costs plus environment and safety concerns have pushed us to consider an air-cooled resistor. Toward that end, we developed a 3 μ s crowbar, with an amplitude threshold of about 3 kA to work in conjunction with the existing crowbar in module two. The fault limiting resistor is reduced to 3 Ω , dissipates 21 kW, and is air cooled. In addition to the crowbar and limiting resistor improvements, we fitted each capacitor with a spring loaded fuse to isolate the capacitor in the event of an internal short. The new crowbar circuit will protect a 30 gauge wire; after 3 months of full operation, there has been no increase in the number of crowbar faults in Module-two. The remaining three modules are scheduled for similar upgrades in late 1997.

Proposed 201.25 MHz Amplifier Replacement

LANSCE is beginning to look into options for replacement of the 7835 PA stage. The primary goal would be to install a new cavity amplifier which will operate as a linear amplifier and eliminate the need for modulation of the high voltage. Modulation of the output power will be done with the RF drive to the preamplifier stage. This will eliminate four more tubes in the system, leaving only two RF amplifier tubes per module. In addition, the voltage overhead of the high voltage modulator will disappear (about 10 kV), so the capacitor bank and HVPS can operate at reduced voltage levels. We hope to be able to replace the 7835 with a single tube amplifier, but we are also considering the use of two tubes which are summed together in a hybrid combiner.

Cathode-driven tetrodes initially designed for fusion heating are the likely choice. There are very few other super-power VHF tubes capable of high duty factor like the 7835. With this power source, we expect to be able to deliver up to 3.8 MW of peak RF power at a duty factor of 15%. This would provide enough RF for long pulse operation of the H+ beam at 21 mA, interleaved with the H- beam for our proton storage ring. This work is in the early stages of design.

Conclusions

Through continuous improvements, the LANSCE 201.25 MHz RF powerplant has reduced from using fifty-two power tubes in 1992 to thirty-six in 1996. Planned upgrades to the IPA and PA stages to remove both plate modulators will reduce this number to only the RF amplifiers themselves, with a total of eight tubes being the optimal design for the high duty-factor requirements of neutron science. Along with the reduction in power tubes, improvements in operational procedures with new diagnostics, stabilization, and protection circuitry have enabled the RF systems to function with exceptional reliability in the past three years.

References

- [1] W.M. Parsons J.T.M. Lyles, and H.W. Harris, "Modulation Improvements in the 201.25 MHz RF Generators at LAMPF," 20th International Power Modulator Symposium, Myrtle Beach, SC, June 23-25, 1992.
- [2] W.M. Parsons, J.T.M. Lyles, and H.W. Harris, "Upgrading the LAMPF 201.25 MHz RF Generators", LA-UR-93-823.
- [3] R. Cliff, E.D. Bush, R. A. DeHaven, H. W. Harris and W.M. Parsons, "Developments and Directions in Two Hundred Megahertz Very High Power RF at the Los Alamos Meson Physics Facility," RF Expo East, Orlando, FL, October 29, 1991.