

CLIC WAVEGUIDE DAMPED ACCELERATING STRUCTURE STUDIES

M. Dehler, I. Wilson, W. Wuensch
CERN, 1211 Geneva 23, Switzerland

Abstract

Studies of waveguide damped 30 GHz accelerating structures for multibunching in CLIC are described. Frequency discriminated damping using waveguides with a lowest cutoff frequency above the fundamental but below the higher order modes was considered. The wakefield behavior was investigated using time domain MAFIA computations over up to 20 cells and for frequencies up to 150 GHz. A configuration consisting of four T-cross-sectioned waveguides per cell reduces the transverse wake below 1% at typical CLIC bunch spacings.

Introduction

Extension of the CLIC scheme to allow operation with trains of 10-30 bunches (30 cm spacing and 8×10^9 particle population) is being studied in an attempt to increase overall efficiency. Such an extension requires a new accelerating structure design that produces suppressed long range wakefields. Preliminary tracking results indicate that the accelerating structure must have a reduction of the transverse wake by a factor of approximately 100 by the time of arrival of a following bunch [1] - including the cumulative effects of all higher order modes. After the time of the following bunch the wake should continue to decrease such that the wake from many bunches does not accumulate.

Wakefield reduction based on detuning has been studied [2], however it does not appear that this scheme provides a sufficient level of performance. The conclusion has persisted even though proposed multibunching parameters have changed significantly since the study was made.

The scheme of wakefield reduction considered here is based on frequency discriminated waveguide damping. Damping waveguides, connected to the outer cavity wall, are chosen to have a cut-off frequency above the fundamental but below all higher order modes - higher order mode energy can propagate out of the accelerating section but the fundamental mode energy cannot.

A number of damping waveguide configurations have been studied using MAFIA. Time domain MAFIA computations were used to determine the transverse and longitudinal wakefields because this direct calculation involves a minimum of assumptions and gives a more or less complete wakefield in a single calculation. In all cases the simplifying assumption of a constant impedance structure has been made. The suitability of a structure design is to be confirmed by beam dynamics simulations that use a computed wakefield.

Computation method

The first step in the study of a candidate geometry was to determine the dimensions needed for a correct fundamental mode frequency by making frequency domain computations. This also gave the fundamental mode Q and R/Q.

Initial time domain calculations over one or two cells followed. If the results looked promising, more accurate calculations of up to 20 cells followed, the number being limited by computer size and speed. The larger number cells gives a more accurate wakefield because it more accurately captures the correct R/Q and phase advance - the discrete set of modes given by a finite cell model does not in general include the synchronous mode of the passband.

The four lowest modes of the damping waveguides were ideally terminated. Thus the assumption that the damping waveguides are nearly perfectly terminated underlies all of the results presented here. The beam pipes were terminated with electrical boundary conditions in order not to over-estimate the damping of the structures.

Design considerations

The transverse wakefield of the CLIC constant impedance geometry is dominated by the lowest, TM_{110} , transverse passband with a number of higher bands contributing at the 5-10% level. The criterion for an acceptable design has been that modes in a wide frequency band, up to about 150 GHz, must be damped.

The basic design features that were used to produce adequate transverse wake damping include: the placement of the waveguides in the cells, the number of waveguides per cell, the waveguide cutoff frequency, waveguide coupling strength and the waveguide cross section.

CLIC disk loaded waveguide is assembled from elements each containing a full iris and a full cell. The waveguides studied here have been restricted to those which could in principle be milled into the top of the element on the cell side. This limitation was imposed to limit the mechanical complexity of the design but it does restrict damping waveguides to being longitudinally off-center in the cells and adjacent to the iris.

A configuration with four waveguides per cell has the advantage of coupling to both polarizations of transverse modes in each cell, and of maintaining a high order of symmetry in the fundamental mode. However the cells become mechanically simpler if the number of waveguides per cell can be reduced. Three waveguides spaced by 120° per cell [3] were considered. This solution damps both

polarizations of the dipole mode and maintains an acceptable symmetry of the fundamental mode. However the symmetry of the structure does not match that of the quadrupole modes and results in a shift of the center of the field pattern (Fig. 1). Near the origin this gives the quadrupole modes a dipole mode characteristic thus increasing the number of dipole modes contributing to the transverse wake. Subsequently only two and four waveguides were considered - the choice being largely determined by the strength of coupling needed.

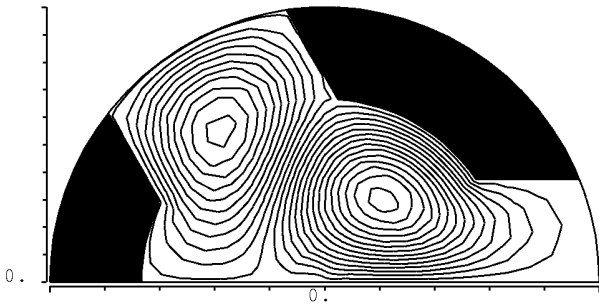

Figure 1: Quadrupole mode in 3-fold symmetric cavity.

The cutoff frequency of the damping waveguide is bounded by an excessive fundamental mode field penetration into the waveguide and consequent loss of R/Q and Q the low side and by the persistent wake [4] on the high side. The persistent wake is a result of the resonance associated with the cutoff frequency of the waveguide - at the cutoff frequency the group velocity goes to zero and the waveguide acts like a resonator. The transverse wakefield has an initial exponential drop-off followed by a wake decreasing with $t^{-1.5}$ as the persistent wake becomes dominant. Lowering the cutoff frequency contributes to suppressing the persistent wake.

The coupling strength of the waveguide to the lowest transverse mode of the accelerating structure also plays a role in the level of the persistent wake. An increased coupling can quicken the initial exponential drop-off but at the expense of increased coupling to the persistent wake and consequently a higher value of the wake for longer times. The coupling can be adjusted by changes in the damping waveguide height (the cutoff frequency remains unchanged) or by adding an iris at the cell-waveguide connection.

The waveguide resonance makes incorporating detuning into the design more difficult as the waveguide cutoff frequency partially determines the frequency of the transverse wake. In addition the varying frequency split between the dipole mode and the fundamental mode along the length of a constant gradient or detuned structure implies varying damping characteristics.

The waveguide (and iris) cross section at the connection point to the cavity wall is the primary means to ensure adequate coupling to the forest of higher order transverse modes including the lowest hybrid TE mode (which itself contributes roughly 0.5 % to the amplitude of the undamped wake). For the class of waveguides considered here the primary difficulty is that the TE_{01} cutoff frequency in

rectangular waveguide is too high to couple to the TE_{11} mode of the cavity. This has been resolved by using a 'T' cross-sectioned waveguide (Fig. 2). This results in two waveguide modes of relatively low cutoff frequency, one of which couples to the TE_{11} cavity mode.

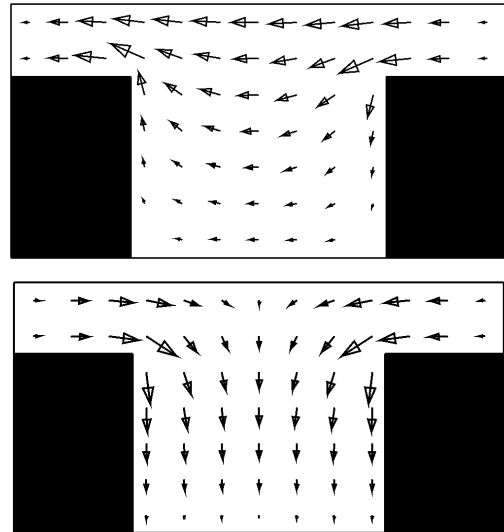

Figure 2: Magnetic field patterns in a T cross-sectioned waveguide.

Design results

The application of the design considerations has led to two waveguide damped disk loaded waveguide designs. One cell and iris of the disk loaded waveguide of each of the designs are shown in Figs. 3 and 4. Successive cells of the two waveguide geometry are rotated by 90° in order to couple to both polarizations of the transverse modes. The wakefield from the structure is shown in Fig. 5.

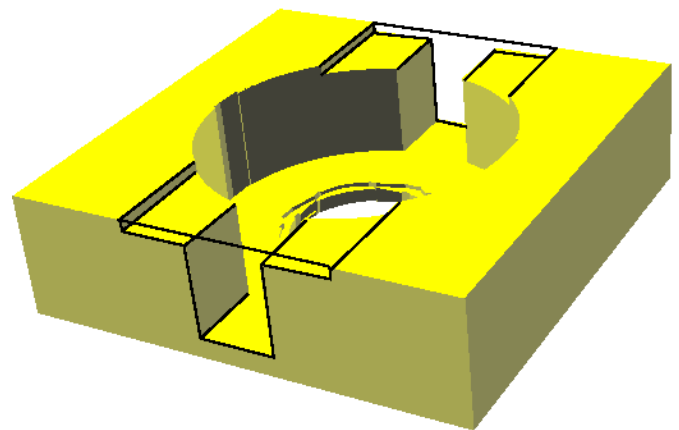

Figure 3: Two waveguide damping.

The primary defect of the design is a substantially reduced Q, 2800 rather than 4400 for the undamped geometry. The Q is lost by the current density concentration around the edges of the top part of the 'T'. Closing of this part of the 'T' off with an iris, as in the geometry shown in figure 4, reestablishes the Q. However four waveguides must be used

in each cell in order to maintain an adequate coupling. The wake from this geometry is shown in Fig. 6.

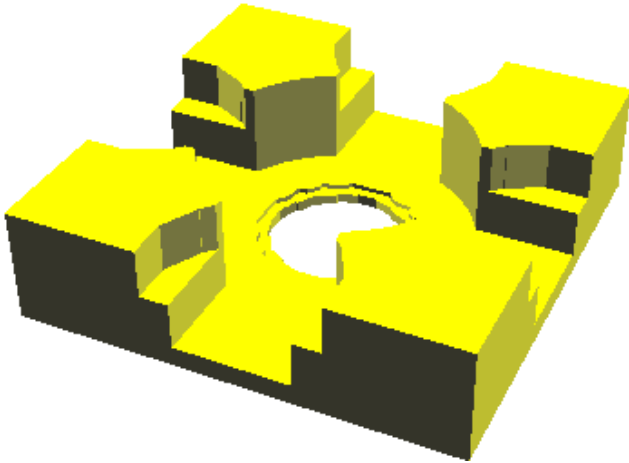

Figure 4: Four waveguide damping with iris.

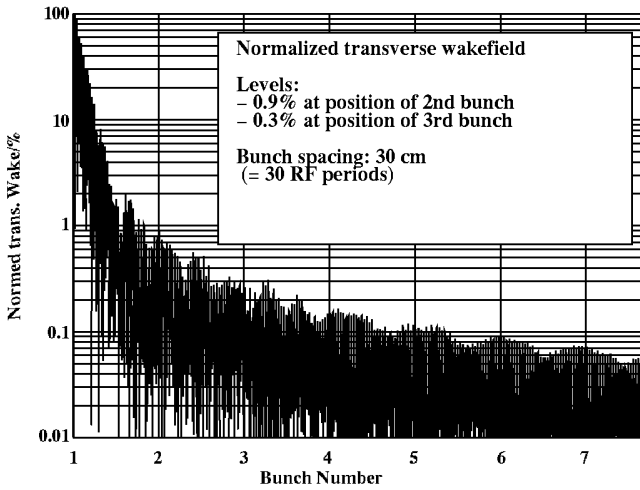

Figure 5: Transverse wakefield from two waveguide geometry computed over 20 cells.

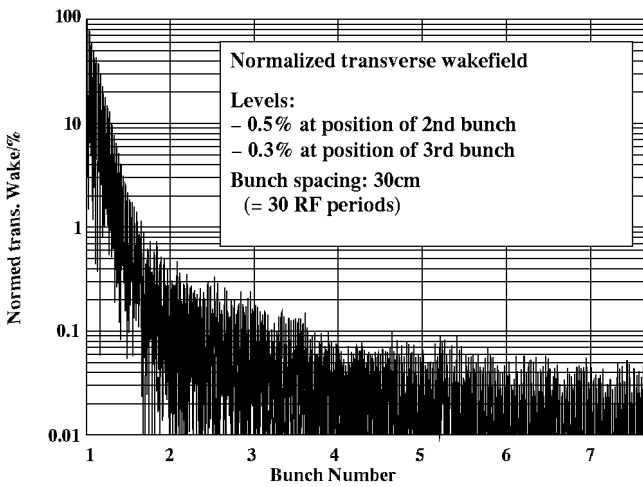

Figure 6: Transverse wakefield from four waveguide geometry computed over 13 cells.

Another perspective on the damping can be seen by comparing the Fourier transforms of the wake from a damped and an undamped (CLIC constant impedance) structure geometry, Fig. 7.

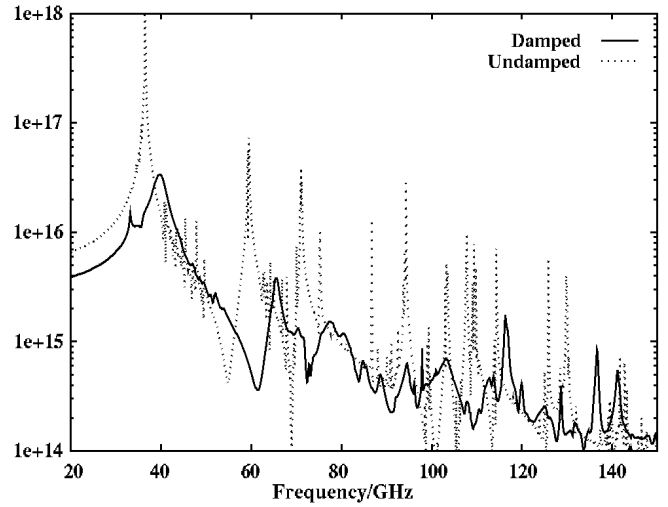

Figure 7: Fourier transform of the transverse wake of the 2 waveguide damped (Fig. 5) geometry and corresponding wake of the undamped geometry.

Conclusions

MAFIA computations have been used to design an accelerating structure geometry with four damping waveguides per cell and to demonstrate that the geometry can produce a reduction of the transverse wake by a factor 100. Beam tracking simulations using the computed wake are now being made to demonstrate that this damping is adequate.

A number of further issues must now be addressed. The effects of imperfect waveguide terminations, the design of a highly compact load effective near the waveguide cutoff frequency, the beneficial effects of adding detuning to the damping and the complications of producing a constant gradient structure must all be considered.

Finally, however, a number of mechanical and fabrication issues have lead to the conclusion that the designs presented here are probably not buildable. An assessment, that includes consideration of mechanical feasibility, of the direction that the study will now take is being made.

References

- [1] G. Guignard and J. Hagel, Multibunch Emittance Preservation in CLIC, proc. EPAC96, Sitges, 1996.
- [2] I. Wilson, W. Wuensch, Multibunch Studies for CLIC, proc. PAC93, Washington, 1993.
- [3] G. Conciauro and P. Arcioni, A New HOM-Free Accelerating Resonator, proc. EPAC90, Nice, 1990.
- [4] N. M. Lin and N. M. Kroll, Minimum Wakefield Achievable by Waveguide Damped Cavity, SLAC-PUB-95-6863.